

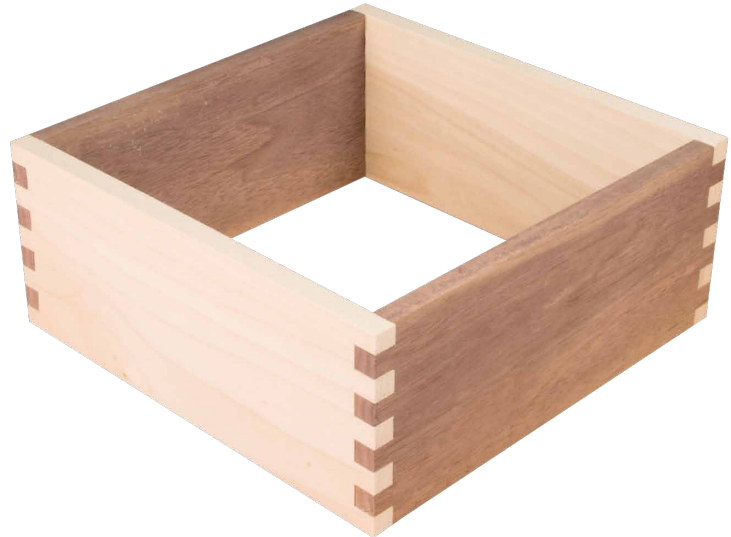

Box Joint Set

Instructions
Part # 3562
Version 1.0



The Fulton™ 8" Box Joint Set must be used with a table saw (contractor or cabinet style) with at least a 1½ HP motor. This set must NOT be used with any other type of machine. Doing so will produce undesirable results and may cause serious injury. The machine that you are using must be stable and free of vibration. For best results your machine should have a run-out tolerance of approx. 0.003". You can check the run-out of your machine by using a standard or digital dial indicator. Please read and fully understand your tablesaw instructions before proceeding.

Safety Tips

1. Always wear safety glasses, hearing protection and dress properly. No loose clothing, hair, draw strings or jewelry that might get caught in moving parts.
2. Keep work area clean. Messy work areas invite injuries.
3. Make deeper or larger cuts in multiple passes and NEVER use dull blades. Forcing a deep cut in one pass or using a dull blade can result in injury. Inspect blades for damage or chips in carbide.
4. Make sure Blades are properly installed in your saw and do not exceed the recommended rpm.
5. Keep all safety guards in place.
6. Always unplug your tools before changing, switching, or making adjustments to the blades.
7. This system is designed for use on tablesaws only, do not use with a radial arm saw, miter saw, chop saw, portable circular saw, etc.
8. Follow all manufacturer safety guidelines provided with your table saw.
9. Carbide is a brittle material that can easily chip or break if dropped or hitting hard materials like stones, staples, nails and so on. Be sure the material you are about to cut is free from foreign materials.
10. Use a Zero Clearance Insert to prevent any material from falling down into the motor well or possibly kicking back. Zero Clearance inserts can be purchased at most any major woodworking retail store.
11. Always double check the security of the blades prior to plugging your machine back in and cutting.

CAUTION:

Please read, understand, and follow all manufacturers instructions, guidelines and owners manuals that come with your power tools. Fulton™ Woodworking Tools & Accessories and its subsidiaries assume no liability for accidents or injuries caused by improper use of this product.

Fulton™ Woodworking Tools & Accessories
P.O. Box 921487
Norcross GA 30010
www.fultonwoodworkingtools.com

What is a box joint?

Box joints are simple joints that are generally used to create decorative corners on boxes, drawers and so on. The joint consists of two main parts: the finger and the notch as shown in the illustration below.

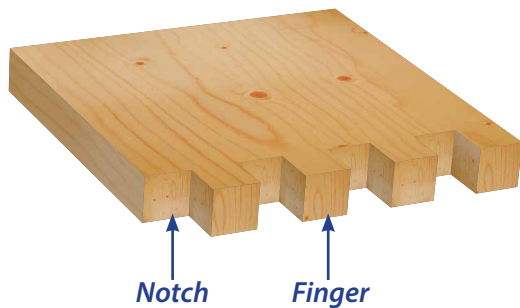

Fulton Box Joint Set

Your new Fulton Box Joint Set will achieve its best results when used with a jig. In these instructions we will detail how to install the blades as well as how to make a quick and simple jig for cutting Box Joints. If so desired, you can also go online and find many different jigs that may be to your liking.

Make the Index Pin

To create the jig we will start by cutting a scrap piece of wood that is large enough to cut safely with your miter gauge. Using the miter gauge cut a notch either a 1/4" or 3/8" into the scrap piece of wood (see image below).



Next, we will make an indexing pin that will act as a reference key when making the notch cuts in your workpiece. The pin should be at least 6" long and made of hardwood. Machine the hardwood pin to the exact size of the notch that you cut in your scrap piece of wood. The indexing pin should fit into the scrap piece notch tightly enough so that it does not fall out but loose enough that it takes only a little bit of force to place it into the notch. Once the pin has been machined to the correct size, cut the pin in half.

Shop Note

The making of the indexing pin is a very important part of the jig making process. Please take the time to do this correctly and as accurately as possible, as this will greatly affect the final results of your joints.

Next, cut a piece of 3/4" plywood to following specifications: 26" long by 6" wide. This piece will be used as the backer board fence on your miter gauge.

Installing the Box Joint Set

CAUTION: *When making any adjustments to the blades, always disconnect the tablesaw from its power source. Failure to do so may result in serious injury.*

The Fulton Box Joint set is designed to cut two different widths of joints. Depending on your project size, you have a choice of either 1/4" or 3/8" joints. To make 1/4" notches, install the blades on to the arbor of your saw with the printed markings on the blades facing out. To make 3/8" notches, install the blades on to the arbor of your saw with the printed marking on the blades facing in. See image below.

1/4" Setup

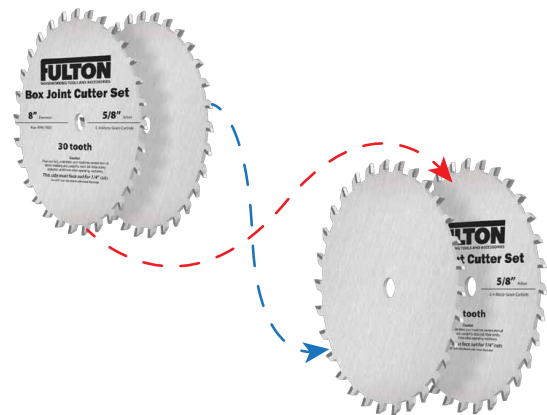

3/8" Setup

The height of your blades should be equal to the thickness of the stock you are using for your project. For example, if your stock is 3/4" thick, the height of the blade should be 3/4" as well.

CAUTION: *Be sure that the teeth on the blades are set to rotate in the proper direction in relation to the tablesaw motor. Before completely securing the blades, make sure the teeth on the two blades are NOT touching. The Carbide teeth should never come in contact with other teeth or any other metal objects. Failure to do so will damage the blades and may cause injury.*

Make the Jig

Disconnect the power source from the tablesaw. Set your fence 13" away from the inside edge of the inner blade on the saw. Stand the backer board fence on edge with one face against the miter gauge on the saw. Place the TWO indexing pins against the tablesaw fence and between the backer board fence as shown in the image below. With a "c" or "f"-clamp, secure the backer board fence to your miter gauge. Remove the indexing pins.

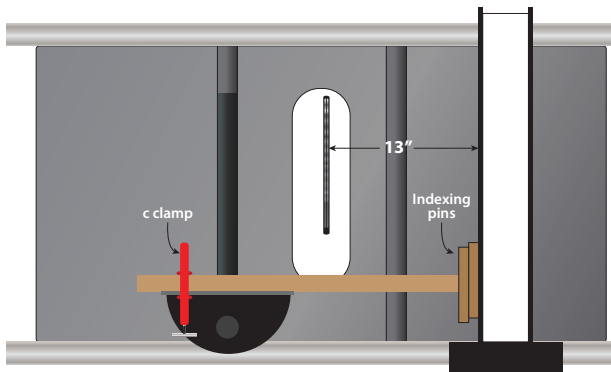

Re-connect the power to your saw. Turn the power on and slide the backer board fence over the blades to cut a notch directly into the backer board fence. Turn the saw off and wait until it comes to a complete stop. Slide the miter gauge and backer board fence back over the blades to its original starting position. Loosen the c-clamp and slide the backer board fence up against the tablesaw fence and re-secure with the "c" or "f"-clamp as shown in the image below.

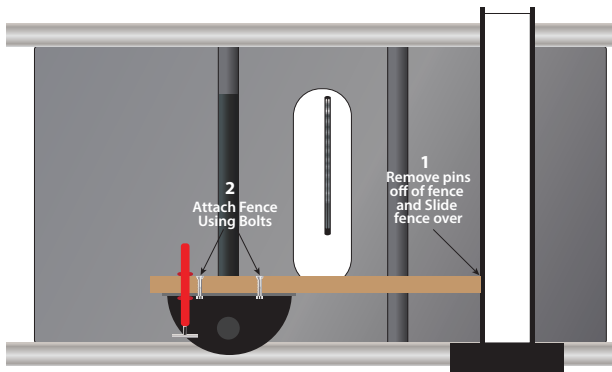

Disconnect the tablesaw from its power source. Most miter gauges have pre-drilled holes for mounting sub-fences to them. If your gauge does not, you will have to drill mounting holes into it. Secure the backer board fence to the miter gauge through the mounting holes using screws or bolts, making sure the head of the screws or bolts do not protrude past the face of the fence.

Now, glue one of the indexing pins into the notch that was just cut. Be sure that at least 3/4 of the length of the pin is sticking out from the face of the backer board fence. See images below. For added strength, you may also nail or screw in the indexing pin after gluing. Keep the other indexing pin for use later when cutting the joint.

Top View

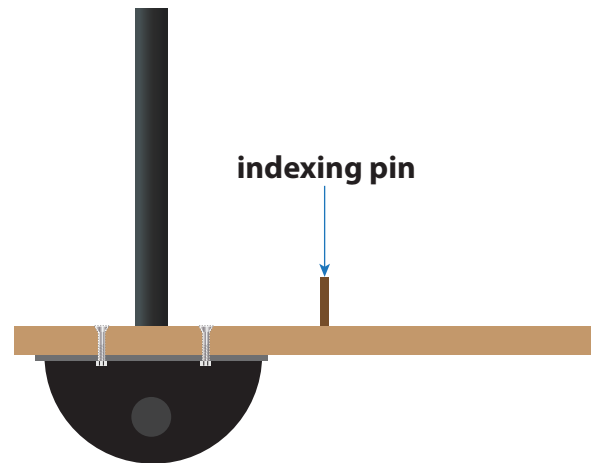

Front Perspective View

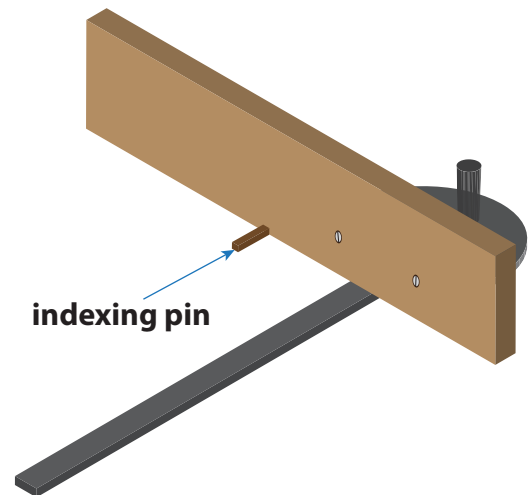

Remove your tablesaw fence from your saw. Your box joint jig is now complete, it's time to start making some beautiful box joints.

Shop Note

Keep in mind that you will need to make two different jigs. You will need one for the 1/4" box joints and one for 3/8" box joints. Each jig is to be made the exact same way with the only difference being the size of the pins and notch cuts.

Cutting the Joints with the Jig

Set your cutter height 1/64" higher than the material you are using for your project. Doing this makes the joint stick out just a little bit. This allows you to sand the joint flush. The unique feature of the box joint set is that it allows you to cut more than one piece at a time. In this example, we are cutting the left and right sides of our box at the same time. We are also going to cut the front and the back at the same time. Start by standing the left and right side of the box on end against the face of our box joint jig. Slide the two pieces over until the one edge touches the indexing pin and secure to the jig with two "c" or "f"-clamps (see image below).



Turn your tablesaw on and with a smooth forward action make your first notch cut through the stock and the jig itself.

CAUTION: Make sure your hand is not in line with the cutters as the blade exits the backside of the jig. Be sure the handle and body of the clamp does not contact the cutter as slide the jig forward

Turn the saw off and wait until it comes to a complete stop. Loosen the clamps and place the two boards onto the indexing pin in the notch cut you just made (see image below).



Repeat this process all the way across the entire width of the stock until it is complete. Repeat this entire process on the opposite end of your side pieces.

Using the other half of your indexing pin as a spacing tool, place the pin against the inside edge of the indexing pin that is fastened to the jig. Take the front and back pieces of your box and stand them on end against the face of your box joint jig. Slide the two pieces over until the one edge touches the indexing pin and secure to the jig with two "c" or "f"-clamps (see image below).



Remove the indexing spacing tool before making your next cut. Turn your tablesaw on and with a smooth forward action make a notch cut through the stock.

Turn the saw off and wait until it comes to a complete stop. Loosen the clamps and slide the two boards over to the indexing pin until the boards touches the side of the notch you just cut (see image below). Now make the cut.



Turn the saw off and wait until it comes to a complete stop. Loosen the clamps and place the two boards onto the indexing pin in the notch cut you just made. Repeat this process all the way across the entire width of the stock until it is complete. Repeat this entire process on the opposite end of your front and back pieces. Your box is now ready for assembly.

